

Product Data Sheet

Description: The EFV-030 Series operate from a 100 ~ 265 V ac input range. These units will provide up to a 24 V of output voltage and a maximum output current of 2500 MA for 30 W maximum output power. They are designed to be highly reliable. Features include over voltage protection, short circuit protection.



1. Universal AC input / Full range
2. Protections: Short circuit / Overload / Over voltage / Over temperature
3. IP67 design for indoor or outdoor installations
4. Cooling by free air convection
5. 100% full load burn-in test
6. High reliability
7. Suitable for LED lighting and moving sign applications
8. Compliance to worldwide safety regulations for lighting
9. Damp / wet location outdoor application
10. 2 years warranty

SPECIFICATION

MODEL		EFV-030-12	EFV-030-24
OUTPUT	DC voltage	12V	24V
	Rated current	2.5A	1.25A
	Current range	0~2.5A	0~1.25A
	Rated Power	30W	
	Voltage tolerance	12V±0.5V	24V±0.5V
	Ripple & Noise	<500mVp-p	
	Power Factor	0.6PF	
INPUT	Voltage range	90~265VAC; 140~350VDC	
	Max AC Current		
	Frequency range	47~65Hz	
	Efficiency (Typ.)	>80%	>81%
	Leakage current	0.5mA/240VAC	
PROTECTION	Short Circuit	short circuit protection	
	Over Temperature	Maximum temperature of components inside the case	
	Over load	3~4A	1.5~2.5A
ENVIRONMENT	Working TEMP	-25°C~50°C	
	Storage TEMP.	-40°C~80°C	
	Working Humidity	IP67	
	Vibration	10~500Hz, 2G 10min/1cycle	
	TEMP. coefficient	±0.03%/°C (0~50°C)	
OTHER	MTBF	20KHours MIL-HDBK-217F (25°C)	
	Dimension	200 x 30 x 20	
	Weight	260g	

Notes: (1) Measured at full load and 220 Vac input.

(2) A suffix –xx may be added to denote variations or modifications to the base product, where x can be any alphanumeric character or blank.

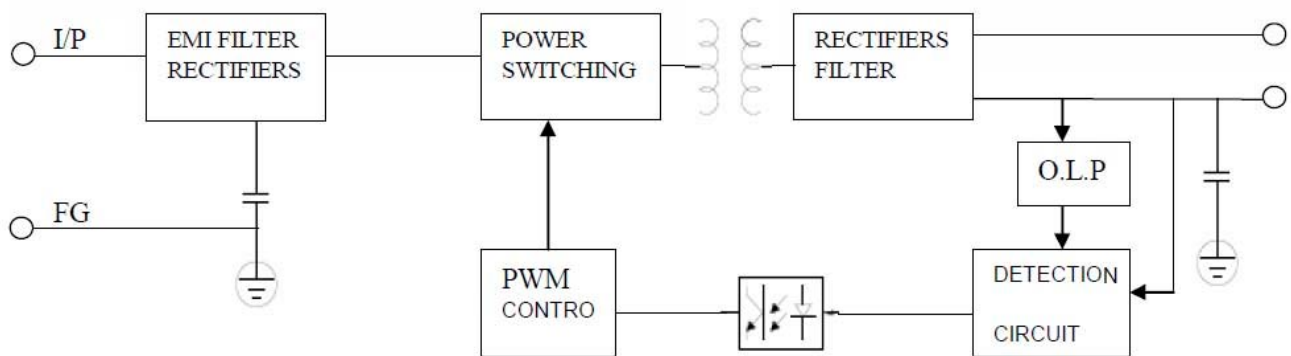
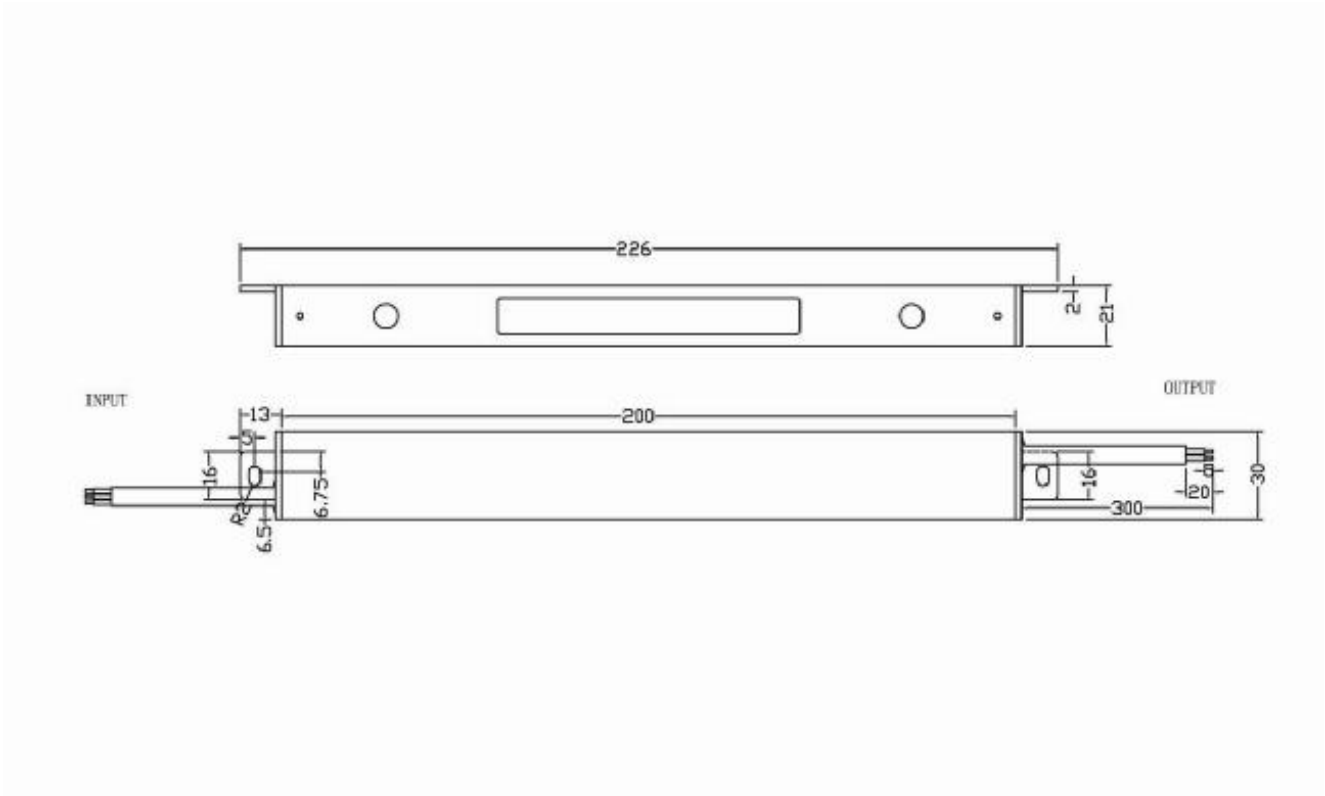

Note: All specifications are typical at 25 °C unless otherwise stated.

No damage shall occur when any output operating in a short circuit condition. The power supply shall be self-recovery when the fault condition is removed.